

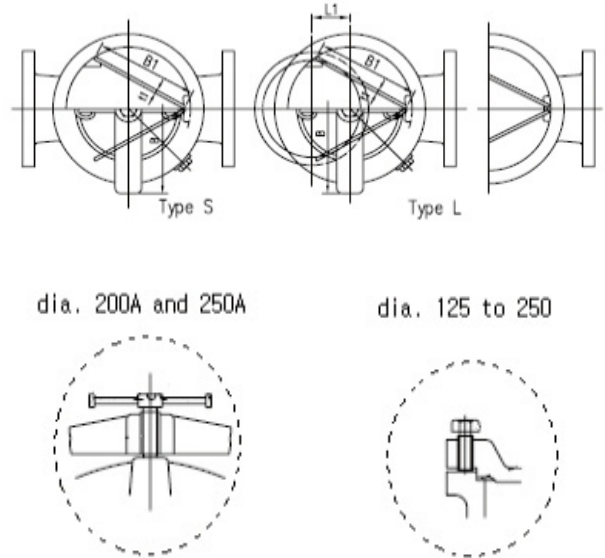

MARINE CAST IRON MUD BOX - JIS F7203

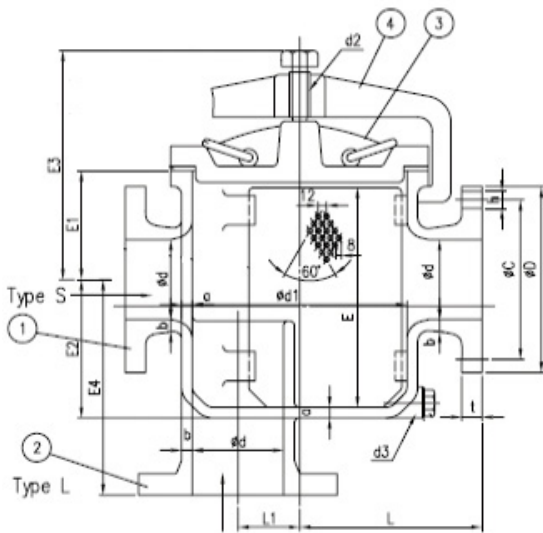

No.	Component	Material
1	Body (Type S)	FC200
2	Body (Type L)	FC200
3	Cover	FC200
4	Yoke of cover	SS400

Nominal dia.	Test Pressure Mpa[kgf/cm ²]
40A to 250A	0.098 [1]

No.	Application	Nominal dia.
S	Main bilge pipe line	40A to 200A
L	Straight tail pipe	40A to 250A

Size	d	L	L1	Flange						Body and cover					E3	E	kg	
				D	C	No.	h	bolt	t	B	E1	E2	E4	d1			S	L
40A	40	90	22.5	120	95	4	15	M12	16	155	55	73	110	85	145	110	10.0	10.5
50A	50	120	40	130	105	4	15	M12	16	225	70	90	135	130	145	135	17.4	17.7
65A	65	150	52.5	155	130	4	15	M12	18	276	90	116	160	170	180	179	28.5	29.7
80A	80	160	55	180	145	4	19	M16	18	296	100	131	180	190	195	203	33.0	34.3
100A	100	190	70	200	165	8	19	M16	20	355	110	152	210	240	225	233	46.3	48.2
125A	125	235	87.5	235	200	8	19	M16	20	433	140	214	285	300	275	323	89.8	92.8
150A	150	280	110	265	230	8	19	M16	22	521	170	267	345	370	320	398	150	156
200A	200	330	135	320	280	8	23	M20	24	660	210	330	440	470	405	490	290	305
250A	250	380	155	385	345	12	23	M20	26	775	280	400	500	560	525	630	-	435